

BEML656 WHEEL LOADER

SALIENT FEATURES

- * Turbo Charged CRS Engine
- * Orbitrol All hydraulic Power Steering
- * Load Sensing hydraulics with Joystick Control
- * Power Shift Transmission with Single lever Control
- * Spacious FOPS Cabin



Bucket Range : 2.1 to 4.5 cu.m (GP)

Operating Mass : 18000 kg

Gross power : 240 hp @ 2300 rpm

www.bemlindia.in

BEML656 WHEEL LOADER

Salient Features :

PRODUCTIVITY

High power Ashok Leyland CRS Engine, rugged transmission, featuring 4 forward and 3 reverse speeds with heavy duty planetary axle, high tractive effort and gradability in all operating conditions.

Load sensing type joystick controlled hydraulic system for work attachment operations,

RELIABILITY

Wet multiple disc brakes for rear and front axle, box type chassis construction for uniform stress distribution.

Z bar linkage assures optimum breakout force and fast cycle time.

MANOEUVRABILITY

Manoeuvrability : Articulation with power steering, optimum combination of travel speed and hydraulic cycle time, turning circle and wheel base.

SERVICEABILITY & MAINTAINABILITY

7" Electronic display and monitoring system helps in better trouble shooting process. Sealed loader linkage pins, account for higher performance and less maintenance. Low maintainability and repairability (SAE J817-A Index) in its class.

COMFORT

Roomy walk through FOPS cab, with ergonomically arranged feather touch control levers and instruments, cushioned and adjustable suspension seat. Excellent visibility assures easy loading and unloading of material.

Steering column mounted single lever electronic control for direction and speed of powershift transmission



ENGINE

Make / Model	Ashok Leyland / H6ETI - CRS
Type	Turbo charged 6 cylinder, Inter cooled Engine
Gross power	240 hp @ 2300 r/min
Bore x Stroke	104 x 113 mm
Maximum torque	800 Nm (81.5 kgm) @ 1700 - 1800 rpm
Governor	Electronically controlled
Lubrication	Forced
Air cleaner	Dry type
Electricals	2-12 V, Dual Battery, Alternator 24V, 85A



TRANSMISSION

Transmission	Full power shift with integral torque converter, 4 forward and 3 reverse speeds, optimally matched with engine power.
Speed (Kmph)	F1 - 6.5 R1 - 6.9 F2 - 12.5 R2 - 13.0 F3 - 24.0 R3 - 25.0 F4 - 37.0



AXLES & FINAL DRIVE

Drive System	All Wheel Drive
Front axle	Full floating type with LSD 30 %, rigid mount
Rear axle	Full floating type with LSD 30 %, trunion mount



BRAKES

Service brake	Hydraulically operated wet multiple disc brake.
Parking Brake	Electro hydraulic actuated, SAHR type fail safe proof



STEERING

Steering mechanism	Fully Hydrostatic power steering independent of engine speed.
Relief pressure setting	230 +/- 10 bar
Steering angle	35 +/- 2 degree



REFILL CAPACITY (Litres)

Hydraulic	130	Engine oil	20
Fuel tank	300	Transmission	21
Engine coolant	40	Rear Axle	24
Front axle	24		



FILTER SYSTEM

Engine	Two stage fuel filter with water separator
Air intake	Dry type, two stage air cleaner with dust evacuator
Hydraulic	Return line filter

STANDARD EQUIPMENT

- 24V starting motor
- 85A Alternator
- 24V/150AH Battery
- FOPS cabin with lockable door, roof lamp and adjustable seat
- Front light
- Electric horn
- Rear view mirror
- Tool kit

OPTIONAL FEATURES

- > Cold starting kit to meet High altitude and extreme cold environmental conditions
- > Axles with dry disc brake
- > AC cabin
- > Rear view camera
- > Centralised lubrication system



HYDRAULICS

Main Pump	Variable piston pump
Capacity	240 lpm @ 2300 rpm
Relief pressure	230 kg/cm ² (23 MPa)
Hydraulic cylinder Qty Bore x Stroke	
Lift cylinder	2 ∅ 140 - 769
Dump cylinder	1 ∅ 200 - 485
Steering cylinder	2 ∅ 90 - 442

Controls :

Controls through hyd joystick pilot operated
Pilot pressure : 30 bar



CABIN CONTROL PANEL

Cabin	FOPS roomy cabin with excellent visibility, fitted with 2 doors & 2 side windows & is rubber mounted to reduce vibration and sound levels
Control Panel	Ergonomically located controls and dashboard for loader operation



BUCKET CAPACITY

SL No	Density of material handled (Kg/m ³)	∅GP Bucket (m ³)
1	2500-2600	2.1
2	2000-2100	2.7
3	1700-1800	3.4
4	1300-1350	4.2
5	1200-1250	4.5



TYRES

Front & Rear : 23.5-25 20PR - 4 nos



MASS (kg)

Operating Mass	18000 kg (including work attachments, coolant, fuel tank and operator)
----------------	--



TURNING CIRCLE DIA

Outside loader bucket	16.5 m
Outside wheels	14.5 m



LOADER PERFORMANCE

Bucket capacity (SAE rated) (General purpose)	3.1 cu.m
Max Dump Height	2782 mm (Tooth Point)
Operating height (fully raised)	5430 mm
Max. Digging depth	385mm
Bucket dumping angle	45 Deg.
Maximum Breakout Force	198 kN
Articulation	35 +/-2 deg

A	Overall length	8000 mm
B	Wheelbase	3300 mm
C	Bucket Width	3086 mm
D	Width over tires	2847 mm
E	Wheel tread	2200 mm
F	Ground clearance	470 mm
G	Overall height, FOPS Cab	3458 mm
	Overall height, FOPS with AC Cab	3674 mm
H	Dump Reach @ 45°(Cutting edge)	1061 mm
	Dump Reach @ 45°(tooth point)	1204 mm
J	Dump Height @ 45°(Cutting edge)	3000 mm
	Dump Height @ 45°(tooth point)	2782 mm
K	Hinge pin height, max. height	4011 mm
L	Operating height (fully raised)	5492 mm
M	Max Digging depth	385 mm

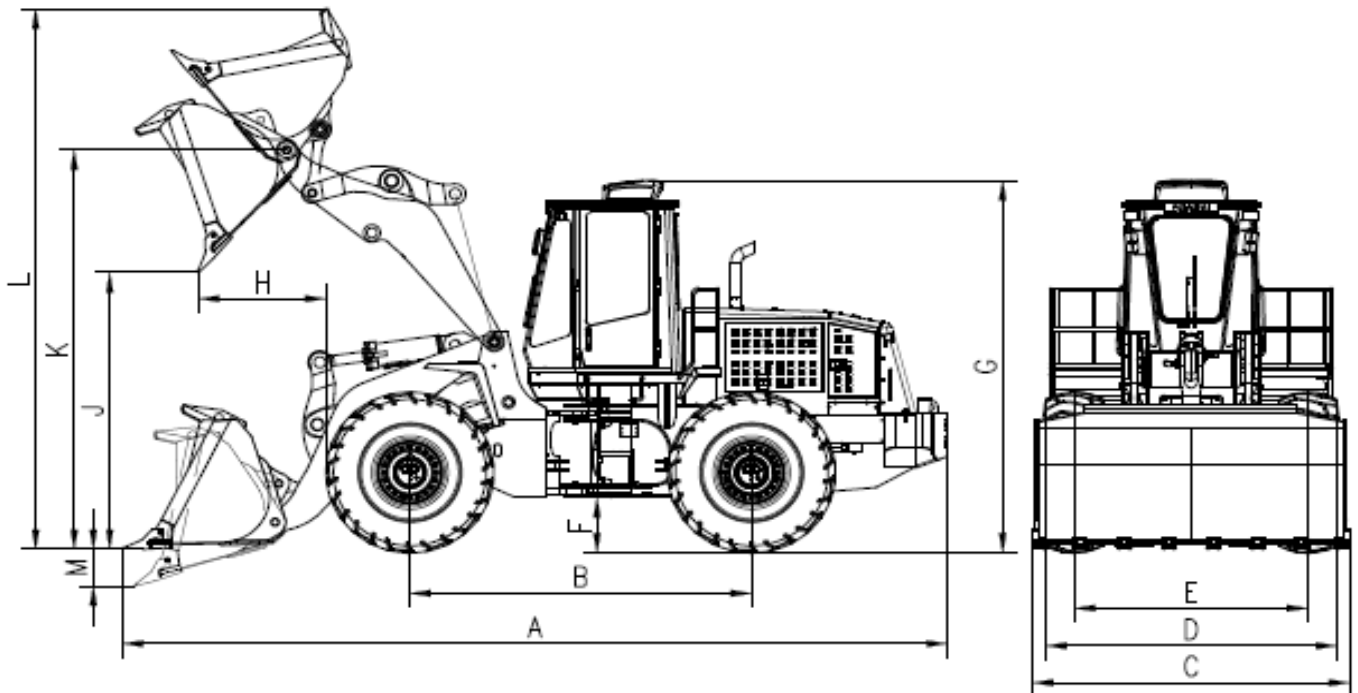

Specifications are subject to change without notice, Illustrations may include optional equipment & accessories

बी ई एम एल लिमिटेड

BEML LIMITED

A Govt. of India Miniratna Company Under Ministry of Defence

Business Network

Corporate Office

BEML Soudha, 23/1, 4th Main,
S.R. Nagar, Bangalore-560 027

T + 91 80 22963240, 22963250

F + 91 80 22963278/516/280/164

E-mail: office@cpd.beml.co.in
office@pr.beml.co.in

International Business Division

BEML Soudha, 23/1, 4th Main,
S.R. Nagar, Bangalore-560 027

T + 91 80 22222730, 22233350
22963187, 22963215

F + 91 80 22224874

E-mail: office@export.beml.co.in

Marketing Division

5th Floor, Unity Building,
J.C. Road, Bangalore-560 002

T + 91 80 22963501/02/07/510/553

F + 91 80 22963541

E-mail: m@beml.co.in
bemdealer@dealer.beml.co.in

Global Service HQ

C-6, Central Hingna Road,
MIDC Industrial Area, Hingna,
Nagpur-440 028

T + 91 7104 287097/287098

F + 91 7104 287099

E-mail: ss.servicehq@gmail.com
ss@servicehq.beml.co.in

REGIONAL OFFICES

Bengaluru

No. 23/1, Haudin Road Cross,
Ulsoor Road, Bengaluru - 560 008
Karnataka.

T + 91 80 22963590
F + 91 80 255581856

Bilaspur

1/A, Sector-C, Sirgitti Industrial Area,
P.O: Tifra, Bilaspur - 495 223.
Chhattisgarh.

T + 91 7752 252745, 252598
F + 91 7752 252065
E-mail: bilaspur@rm.beml.co.in

Chennai

Flat No. 10&11, Supriya Estates,
Sterling Road, Nungambakkam,
Chennai - 600 034, Tamil Nadu

T + 91 44 28276576 / 28220844
F + 91 44 28257319
E-mail: chennai@rm.beml.co.in

Dhanbad

Kamal Kunj, Kola Kusuma,
Saraidhela, Dhanbad - 828 127
Jharkhand

T + 91 326 2200180 / 2208982/5827
F + 91 326 2200182
E-mail: dhanbad@rm.beml.co.in

Hyderabad

3-6-114, Himayat Nagar,
Hyderabad - 500 029
Andhra Pradesh

T + 91 40 23225250 / 7032 / 2166
F + 91 40 23221794
E-mail: hyderabad@rm.beml.co.in

Kolkatta

35/1, Taratala Road,
Kolkatta - 700 088.
West Bengal

T + 91 33 24015286 / 87 / 98 / 99
F + 91 33 24015288
E-mail: kolkatta@rm.beml.co.in

Mumbai

Rajmahal, 84 Veer Nariman Road,
Church Gate,
Mumbai - 400 020, Maharashtra

T + 91 22 22042533 / 22049490
F + 91 22 22852633
E-mail: mumbai@rm.beml.co.in

Nagpur

33, Cement Road,
Shivaji Nagar,
Nagpur - 440 010, Maharashtra.

T + 91 0712 2248435 / 2248343
F + 91 0712 2249997
E-mail: nagpur@rm.beml.co.in

New Delhi

Flat EFGH, 'Vandana', 11th Floor,
Tolstoy Marg,
New Delhi - 110 001

T + 91 11 23310035 / 23316500
F + 91 11 23325085
E-mail: delhi@rm.beml.co.in

Ranchi

206/D-1, Bhagirathi, (Behind NCC Campus),
Rameshwaram Colony, Barlatu Road,
Ranchi, Jharkhand - 834009

T + 91 651 2540710 / 2540791
F + 91 651 2540624
E-mail: ranchi@rm.beml.co.in

Sambalpur

BEML Complex, NH-6, Baraipalli,
Sambalpur - 768 150
Orissa.

T + 91 663 2521604 / 2520393
F + 91 663 2521603
E-mail: sambalpur@rm.beml.co.in

Singrauli

PB No. 5, Jhingurdha Colliery,
Sidhi, Singrauli - 486 889
Madhya Pradesh.

T + 91 7805 268260 / 266668
F + 91 7805 267282 / 318
E-mail: singrauli@rm.beml.co.in

www.bemlindia.com

Represented by :



DISTRICT OFFICES

Ahmedabad

266-1, Dilbaug Villa,
Darshan Society Road, Navrangpura,
Ahmedabad - 380 009. Gujarat

T + 91 79 26445523
F + 91 79 26423950
E-mail: ahmedabad@rm.beml.co.in

Asansol

3, Bumpur Road,
Asansol - 713 304
West Bengal

T + 91 341 2252480
F + 91 341 2250601
E-mail: asansol@rm.beml.co.in

Bacheli

Behind Central Stores
of NMDC Ltd., Depot 5, Bacheli - 494 553.
Chhattisgarh

T + 91 7857 200518
F + 91 7857 230005
E-mail: bacheli@rm.beml.co.in

Bhilai

Room No. 22/C, BSP Building,
Near Ispat Bhavan, Bhilai - 490 001
Chhattisgarh.

T + 91 788 2223882, 2894721
F + 91 788 2221652
E-mail: bhilai@rm.beml.co.in

Bhopal

Ground Floor, Hall No.1, Chittod Complex
Zone-1, Maharanapratap Nagar (MP Nagar)
Bhopal - 462 023

T + 91 755 2550711
E-mail: bemlbhopal@gmail.com

Bhubaneswar

252/A, LEWIS Road,
Bhubaneswar - 751 014
Orissa

T + 91 674 2434428
T/F + 91 674 2434427
E-mail: bhuvaneshwar@rm.beml.co.in

Chandrapur

Mamidwar, Tiles Factory Compound,
Ghugus Road, Padoli,
Chandrapur - 442 406 Maharashtra

T + 91 7172 287230
F + 91 7172 287072
E-mail: chandrapur@rm.beml.co.in

Cochin

No. 55/845, Chittoor Road, Ernakulam South
Cochin-682 016

T + 91 484 2375138
E-mail: bemkochi@gmail.com

Guwahati

Hegrabari Road, House No. 11,
Ganesh Puri, Dispur,
Guwahati - 781 006 Assam

T + 91 361 2232966
F + 91 361 2232967
E-mail: guwahati@rm.beml.co.in

Hospet

L-8, KSSIDD Industrial Area,
Dam Road, Hospet - 583 203
Karnataka

T + 91 8394 223173
F + 91 8394 230172
E-mail: hospet@rm.beml.co.in

Jammu

62C, Block D/C, Gandhi Nagar,
Jammu tawi - 180 004
Jammu and Kashmir

T + 91 191 2430447
F + 91 191 2477469
E-mail: jammu@rm.beml.co.in

Kothagudem

Old Project Planning Department,
Near SCCL Corporate Office,
Kothagudem - 507 101, Andhra Pradesh

T + 91 8744 245572
F + 91 8744 245530
E-mail: kothagudem@rm.beml.co.in

Madurai

9-4/49, Kalai Nagar, IInd Main Road,
Madurai - 625 017, Tamil Nadu.

T/F + 91 452 2649458
E-mail: madurai@rm.beml.co.in

Neyveli

F-4, Rajendraprasad Road, Block-27
Neyveli - 607 803. Tamil Nadu

T/F + 91 4142 268517
E-mail: neyveli@rm.beml.co.in

Goa

67-12, Dattaprasad Building, III Floor, MG Road,
Timphoni School, Panjim - 403 001. Goa

T/F 91 832 2225135
E-mail: goa@rm.beml.co.in

Ramagundam

Opp. SCCL 11A Mines, Manthani,
(PO) Jallaram, GK - 505 184
Karimnagar Dt. Andhra Pradesh

T + 91 8728 248299
F + 91 8728 247423
E-mail: ramagundam@rm.beml.co.in

Udaipur

20-B, Uchhab Bhawan, Bedia Road,
Fatehpura, Udaipur - 313 004.
Rajasthan

T + 91 294 2452053, 2452055
F + 91 294 2452054
E-mail: udaipur@rm.beml.co.in

Visakhapatnam

No. 8-45-11, 4h Lane, China Weltair Colony,
Visakhapatnam - 530 003

T/F 0891 2754608
E-mail: vizag@rm.beml.co.in

बी ई एम एल लिमिटेड

BEML LIMITED

A Govt. of India Miniratna Company Under Ministry of Defence